

**Existing 290' building height limit
(as adopted on April 30th, 2008):**

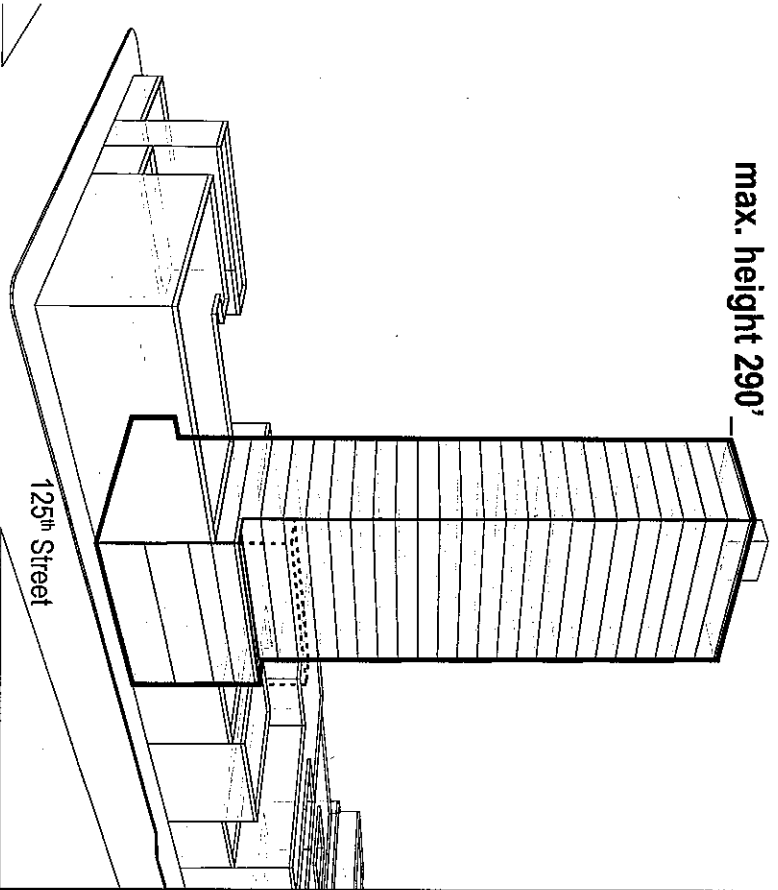

Proposed 195' building height limit:

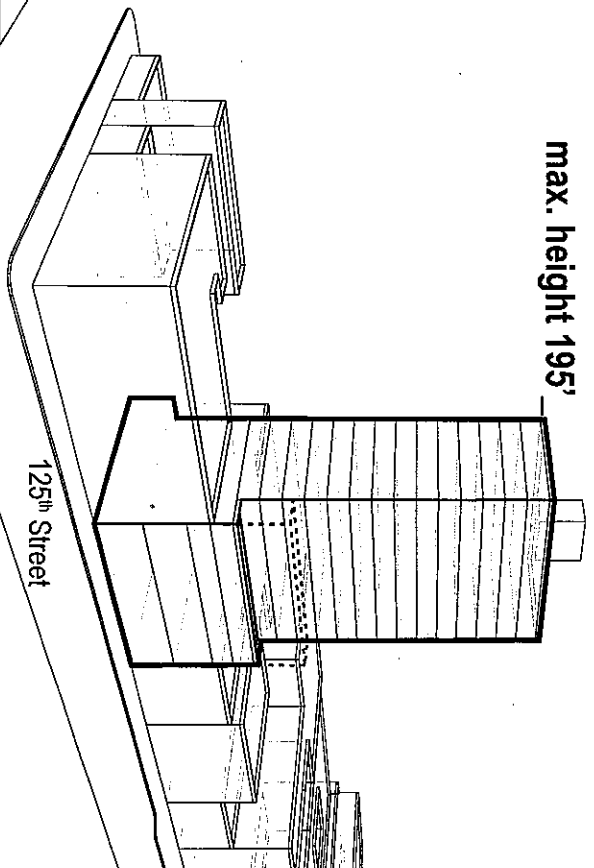

Allowed Density within Special District

use:	base FAR:	max. FAR:	bonus type:
C	10	12	arts
R	9	12	arts or IH
CF	-	10	-

Allowed Density within Special District

use:	base FAR:	max. FAR:	bonus type:
C	7.2	8.65	arts
R	5.4	7.2	arts or IH
CF	-	7.2	-

SPECIAL 125TH STREET DISTRICT
CORE SUBDISTRICT

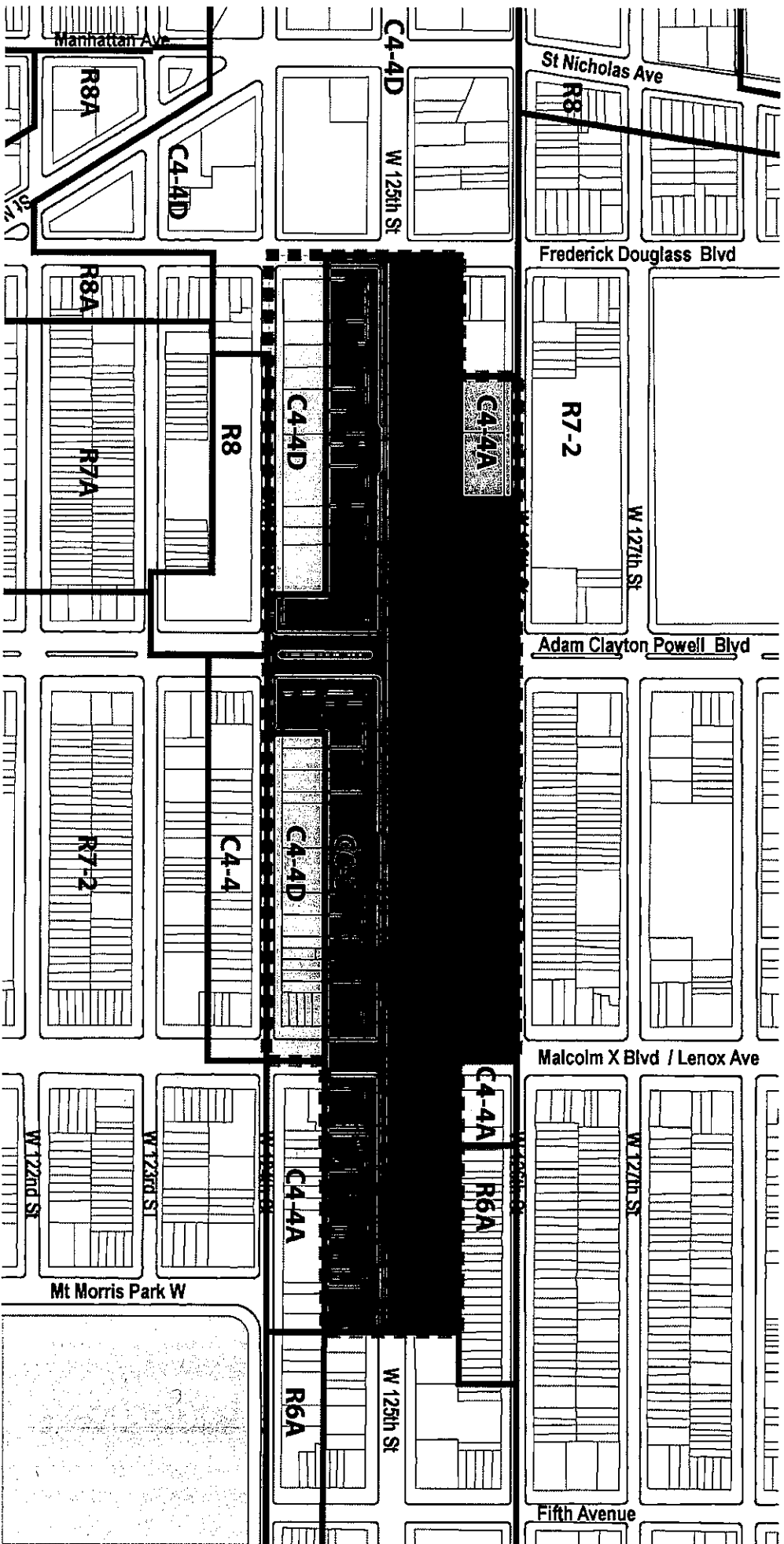

SPECIAL 125TH STREET DISTRICT ZONING

Rezonning Area and Special District Boundaries

SPECIAL 125TH STREET DISTRICT ZONING - As adopted on April 30th, 2008

Answer Density within Special District (FAR):

Use	Residential	Commercial	Community	Special District bulk controls
Underlying District	Residential Max FAR	Commercial Max FAR	Community Max FAR	Building Area min. max.
R8	3.0	4.0	3.0	40' 50' 70'
R7-2	3.44	4.0	5.5	not required none
R7A	-	2.0	4.0	40' 65' 80'
C2-4	-	-	-	-
C2-4 overlay	-	4.0	4.0	40' 65' 80'
C4-1A	4.0	4.0	4.0	40' 65' 80'
C4-1D	5.4	4.0	6.0	60' 85' 120'
CS-3	5.4	1.4	6.0	60' 85' 120'
CS-3 (low)	6.0	2.0	6.0	60' 85' 160'
C4-7	8.0	3.0	12.0	60' 85' 280' 330'

* MAX BULKING

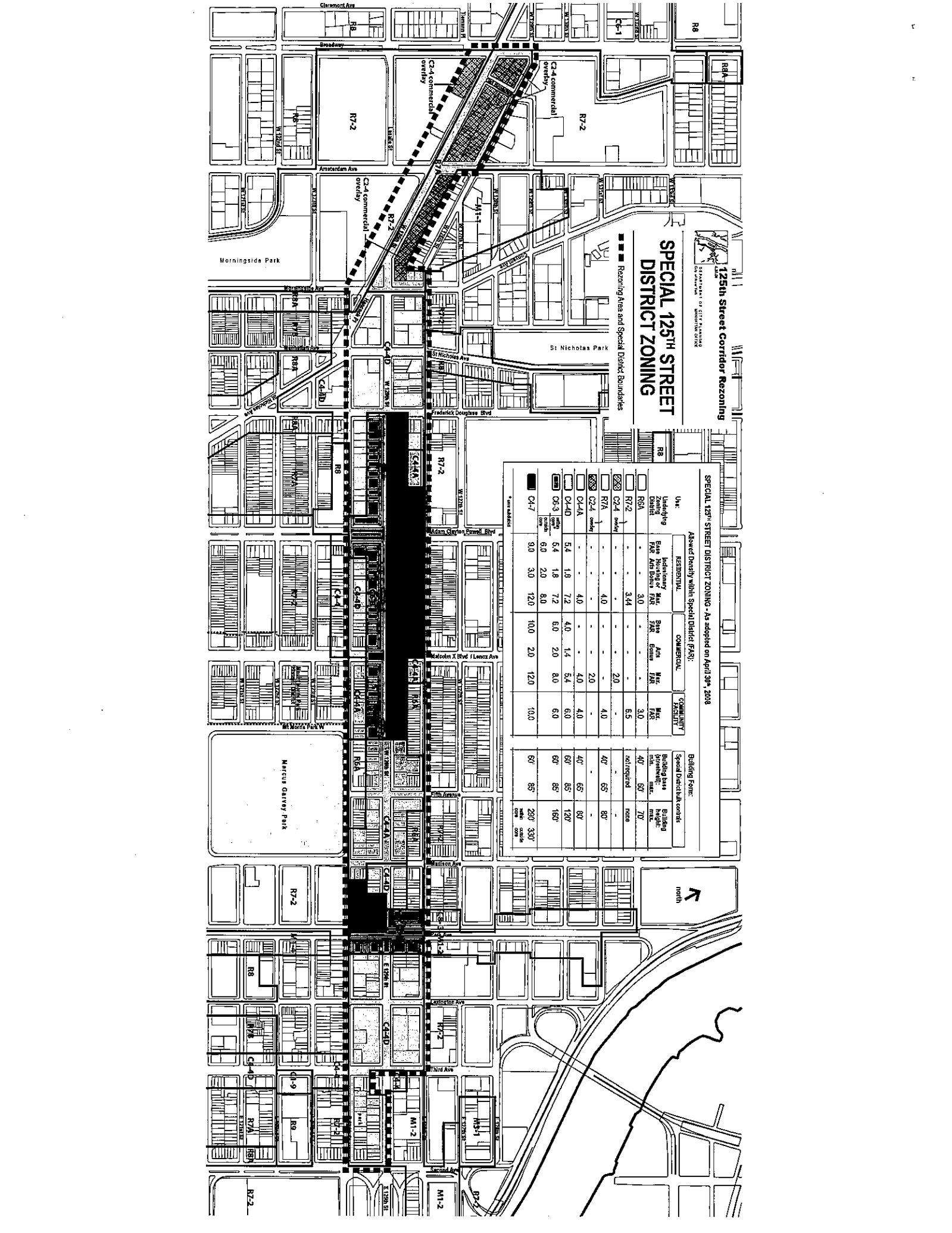

**THE COUNCIL
THE CITY OF NEW YORK**

Appearance Card

I intend to appear and speak on Int. No. _____ Res. No. LV922
 in favor in opposition

Date: 11/17/08

(PLEASE PRINT)

Name: Edwin Marshall
Address: Manhattan Borough Office
I represent: NYC Department of City Planning
Address: 22 Reade St NY, NY 10007
6th Floor

Please complete this card and return to the Sergeant-at-Arms

**THE COUNCIL
THE CITY OF NEW YORK**

Appearance Card

I intend to appear and speak on Int. No. _____ Res. No. LV922
 in favor in opposition

Date: 11/17/08

(PLEASE PRINT)

Name: Jaime Ortiz
Address: Manhattan Borough Office
I represent: NYC Department of City Planning
Address: 22 Reade St, 6th Fl - NY, NY 10007

Please complete this card and return to the Sergeant-at-Arms